



# *MillMinder*

## **AUDIO SIGNAL MONITOR**

**IM-1**

**JUNE 1999**

USA: 6428 Ridglea Drive, Watauga, Texas 76148  
Tel/Fax 1-817-427-2060/2067  
E-mail: [westec@flash.net](mailto:westec@flash.net)

# CATALOG NUMBERING SYSTEM

MILLMINDER

9 0 2 0 \_ \_ \_ 2

0 OPEN STYLE

1 NEMA 4 STEEL

2 NEMA 4X SS

1 115V 50/60 HZ

2 230V 50/60 HZ

1-5 NUMBER OF CHANNELS

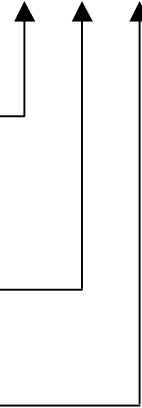

MILLPHONE

6 1 0 0 1 0 1 1

## SPECIFICATIONS

POWER SUPPLY

- 115 VAC, 50 / 60 HZ, 20 VA – STANDARD
- 230 VAC, 50 / 60 HZ, 20 VA – OPTIONAL

ENCLOSURE

- NEMA 4 MILD STEEL
- NEMA 4X 304 STAINLESS STEEL
- 20"H X 16"W X 7.5"D

INPUT

- MILLPHONE

OUTPUT

- ONE PER CHANNEL, EACH WITH AN INDIVIDUAL ZERO AND SPAN TO ALIGN RECORDER TRACE OR TO SUIT SPECIAL CALIBRATION
- 4-20 MA INTO 750 OHMS MAX.
- ALL NEGATIVE TERMINALS ARE ON A COMMON BUS

# INSTALLATION

## MODULE RACK

The Module Rack should be mounted in an area that is clean, dry, vibration free, within the equipment's ambient temperature range and non-corrosive to the electronics or the enclosure if supplied. The enclosure door should swing fully, allowing access for wiring and calibration.

DO NOT MOUNT THE MODULE RACK IN DIRECT SUNLIGHT

Refer to figure 1 for mounting dimensions and remove the Module Rack from the enclosure when drilling for conduit or cable entrance.

## MILLPHONE

The millphone location on the mill shell is extremely critical as there may be only a small specific area where the sound signal is actually inversely proportional to the mill load. Some locations will have sound signal reversals, that is, for a further decrease in actual load the mill will start to become quieter.

Therefore, the mounting brackets must allow for a large variation in microphone location so that the final location can be determined during start-up of the control system. Refer to figure 2 for mechanical dimensions and figure 3 for the area of the mill shell that must fall within the adjustment range of the microphone.

## INTERCONNECTION and CABLING

ALL WIRING MUST BE DONE IN CONJUNCTION WITH APPROVED  
CONDUIT, BOXES AND FITTINGS AND TO PROCEDURES IN  
ACCORDANCE WITH ALL GOVERNING REGULATIONS.

The Module Rack and millphone (s) should be interconnected per figure 4. The cabling should be a two wire twisted shielded pair from the microphone to the Module Rack. Use Belden 8760 or equivalent to a maximum run of 1,000 feet.

The mA output signal cabling can also be Belden 8760, to a maximum run of 2000 feet.

Cabling should be run in separate conduits or in instrument cable trays per standard instrumentation practices. The microphone signals are low-level millivolt A.C. and deserve the consideration these types of signal levels require.

**Millphone locations are identified in the application bulletins in the back of this manual.**

# OPERATION

## APPLICATIONS

The MillMinder is a mill load level sensing system used to monitor the sound (noise) emanating from a grinding mill. The millphone assembly placed below the point of impact between the mill charge and the mill shell detects the predominantly audible frequencies. The millphone / sound sensor transmits its signal to an amplifier / converter where the signal at a selected frequency is amplified and converted to an analog mA output signal.

## CIRCUIT DESCRIPTION

The MillMinder contains the following cards

1. Module Rack ..... MR-50
2. Voltage Regulator Card VR-50
3. Meter Card ..... MC-50
4. Sonic Sensor Card..... SS-50

### MODULE RACK, MR-50

The MR-50 is supplied with 115 VAC (or optional 230 VAC) power supply. The supply line is wired into terminal block 6TB. There is a set of fused (5A Slo-Blo) auxiliary supply terminals provided. An On / Off power switch is supplied for the MR-50 but the auxiliary supply is not switched. A ¼AMP Slo-Blo (1/8 Amp for 230 VAC units) fuse protects the supply line and a surge suppressor is used to protect the circuitry from high surges in the supply. The transformers and large filter capacitors for the power supply are mounted on the MR-50 Module Rack.

### VOLTAGE REGULATOR, VR-50

The VR-50 consists of three power supplies for the system. The card is plugged into 7ECN on the MR-50 Module Rack.

There is a +5V bus, with D COMMON, for the digital circuitry, a +24V bus, with P COMMON, for the relay driver circuits, and a +15V and -15V bus, with A COMMON for the analog circuitry. The three commons are connected together on the VR-50 card, but are to be wired as separate COMMON busses at the terminal block 7TB on the MR-50.

The four LED's indicate when the power supply is ON. If the supply is less than rated, the LED will be dimmer than normal.

## METER CARD, MC-50

The MC-50 is a 0 to +10 VDC meter which is used during set-up and calibration.

The MC-50 consists of a full wave precision rectifier to assure that there will be a positive voltage to the meter regardless of the polarity of the input signal.

The input signal connected at test point TP2 (Red) is fed through a buffer, IC1-c. The signal is applied directly to an inverting amplifier, IC1-a, and through a half wave rectifier, IC1-b.

If the input is a negative voltage the voltage at the anode of D1 will be zero. Therefore, the output of IC1-a is the inverted signal.

If the input is positive voltage the output of IC1-b will be the inverted input signal. This is summed with the input signal. The output of IC1.a is the input signal plus twice the inverted input signal.

The signal is available at the test point TP1 (Yellow) for connection to an auxiliary meter.

The COMMON test point TP3 (Green), is used when measuring a signal from equipment other than the MR-50 and for use with an auxiliary meter.

The LED signifies a negative voltage input.

## SONIC SENSOR CARD, SS-50

The SS-50 is an input card for the millphone signal. The cards are plugged into edge connectors 1ECN to 5ECN on the MR-50 Module Rack, one per channel (millphone). The SS-50 consists of a signal conditioner, limit circuitry and a voltage to current converter.

The signal conditioner consists of a two-stage amplifier with fine and coarse gain control, an active filter with adjustable center frequency dependent upon the type of mill being controlled (refer to Page 8 for  $R_A$  and  $R_B$  values for a specific frequency), and a full wave precision rectifier with an offset and gain control.

The two stage amplifier consists of IC1 and IC2 with coarse gain control SW1, and fine gain control (P1) GAIN A. R24A is used as a load resistor for the microphone's transformer secondary. The gain ranges from 0.25 to 54.

The signal is then processed through an active band pass filter, IC3 to amplify the desired frequency. The center frequency of the filter is selected with the

FREQUENCY switch, SW2. Position 1 is 3.3 KHz, position 2 is for 1 KHz, and position 3 is for a custom frequency.

The full wave precision rectifier consists of a half wave rectifier (IC4-a) and an inverting amplifier (IC4-b).

The voltage at the anode of D2 will be zero when the signal is negative. When the input is positive the voltage will be the inverted input.

Therefore, the output of IC4-b will always be positive when the OFFSET voltage is zero. The output of IC4-b can be doubled with GAIN B. This signal can be seen at the Blue test point TP3, (V in). This voltage varies from 0 to 10 VDC for an input signal level of 1 to 100%.

'V in' is connected to an amplifier whose output is offset by a voltage of  $-10V$ . This signal is a 0 to 10 VDC signal proportional to the load of the mill and is available at the Yellow test point TP2, (V out).

'V out' is converted to an analog mA output signal with ZERO and SPAN adjustments. The circuitry will maintain a stable current output signal referenced to COMMON throughout the rated load.

The circuitry is basically a closed loop regulating feedback system. 'V out', which has SPAN adjustment, is summed at the input IC6-a with the feedback signal, which is proportional to the current flow. IC6-a acts as a very high gain comparator. There is an offset current adjustment via the ZERO potentiometer at this summing junction. Any error between the two signals will cause the output current flowing through sensing resistor R65 to vary in a direction to reduce the error to zero. IC6-b functions as a unity gain inverter driving the level shifting circuitry consisting of Q1 and R64 which drives the current output transistor Q2.

It is important to note that the output voltage developed across the current sensing resistor, R65, will float with respect to COMMON, a varying amount dependent on the externally connected op amp with a very high common mode rejection ratio, and ensures that the floating current signal is sensed accurately.

In order to achieve the required high common mode rejection, it is necessary to observe the design requirement that the ratio of R63 to R73 is the same ratio of R77 to R75. The requirement is achieved by using 1% resistors and inserting a small trim-pot, P9, which may be adjusted to achieve the required exact ratio. P9 is a sealed factory adjustment.

The output of IC6-c is connected to a voltage follower, IC6-d, to give a voltage signal representing the current output with ZERO and SPAN adjustments.

# CALIBRATION

## SS – 50 Set-up Procedure

The following settings are preset at the factory:

P1	Gain A	CCW
P2	Offset	CCW
P3	Gain B	CCW
P4	Limit	CW
P5	Rate	CW
P7	Zero	Do Not Adjust
P8	Span	Do Not Adjust
SW1	Gain	Position 1
SW2	Frequency	Select Position from Table Below

<u>Device</u>	<u>Position</u>
Cement – Finish	1
Cement – Raw, Dry	1
Cement – Raw, Wet	2
Coal	1
Aerofall	3
Autogeneous	3
Rod Mill	3

## Dynamic Adjustment to First Compartment (With mill running at normal levels)

- 1.1 Connect a meter between V IN test point TP-3 (Blue) on the SS-50 card to the SIGNAL test point TP-2 (Red) on the MC-50 meter card.
- 1.2 Adjust coarse GAIN switch (SW1) until the meter reads between 1 and 5 VDC.
- 1.3 Adjust fine GAIN A (P1) potentiometer clockwise until meter reads 5 VDC.
- 1.4 Connect the jumper from TP-2 (Red) on the meter card to V OUT test point TP-2 (Yellow) on the SS-50 card. The reading should be 5 VDC +/- 0.5.
- 1.5 Adjust the RATE potentiometer (P5) on the SS-50 card until the meter reading has about a 0.5 to 0.75 volt short term bounce.
- 1.6 ZERO (P7) and SPAN (P8) have been factory set to provide a 4-20 mA output with a V OUT change of 0 to 10 VDC.

## Dynamic Adjustment to Second Compartment

- 2.1 Connect a meter between V IN test point TP-3 (Blue) on the SS-50 card to the SIGNAL test point TP-2 (Red) on the MC-50 meter card.
- 2.2 Adjust coarse GAIN switch (SW1) until the meter reads between 1 and 5 VDC.
- 2.3 Adjust fine GAIN A (P1) potentiometer clockwise until meter reads 5 VDC.
- 2.4 Adjust GAIN B (P3) potentiometer clockwise 10 turns. The meter reading should now be less than 5 VDC.
- 2.5 Adjust the OFFSET (P2) potentiometer until the meter reading is 5V.
- 2.6 Connect the jumper from TP-2 (Red) on the meter card to V OUT test point TP-2 (Yellow) on the SS-50 card. The reading should be 5 VDC +/- 0.5.
- 2.7 Adjust the RATE potentiometer (P5) on the SS-50 card until the meter reading has about a 0.5 to 0.75 volt short term bounce.

## Increasing Sound Sensitivity to Load Changes (When required)

The need for this adjustment will be determined during actual automatic start-up and automatic operation.

- 3.1 Follow steps 2.1 – 2.3
- 3.2 Instead of following step 2.4, turn GAIN B (P3) potentiometer clockwise 5 turns.
- 3.3 Observe sound change results.
- 3.4 If sound changes are deemed not to be significant enough, increase GAIN B two turns at a time until results are satisfactory.
- 3.5 Complete steps 2.5 – 2.7

## 4-20 mA Trace Relocation

There are occasions when the trace created by the 4-20 mA output on a recorder may not be located correctly or interferes with another trace on a multi-trace recorder. The 4-20 mA potentiometers may be adjusted to match the recorder trace.

- 4.1 Jumper terminals 1 and 2 on the TB 1 through 5 associated with the correct SS-50 card.
- 4.2 This will cause the V OUT signal to go to 10 VDC (or close to it).
- 4.3 Adjust the SPAN (P8) until the desired output current or recorder trace position is achieved.

## Fine Tuning from the Frequency Chart

Center frequencies may be adjusted by bridging various value resistors across RA and RB plug points. Refer to the following chart for correct values:

Device	Frequency (Hz)	RA & RB Values
Cement - Finish	3300	10 K
	2500	12.9 K
Cement - Raw, Wet	1000	32.4 K
Cement - Raw, Dry	3300	10 K
	1000	32.4 K
	750	42.5 K
Aerofall	3300	10 K
	2100	15.2 K
	1750 (Wet)	18.2 K
Coal	3300	10 K
Rod Mill	8000	
	1800	17.8 K
	350	90 K
Cascade	1000	32.4 K
	1750	18.2 K
	2100	15.2 K
	3300	10 K
Regrind Mill	3300	10 K
	1000	32.4 K
	350	90 K

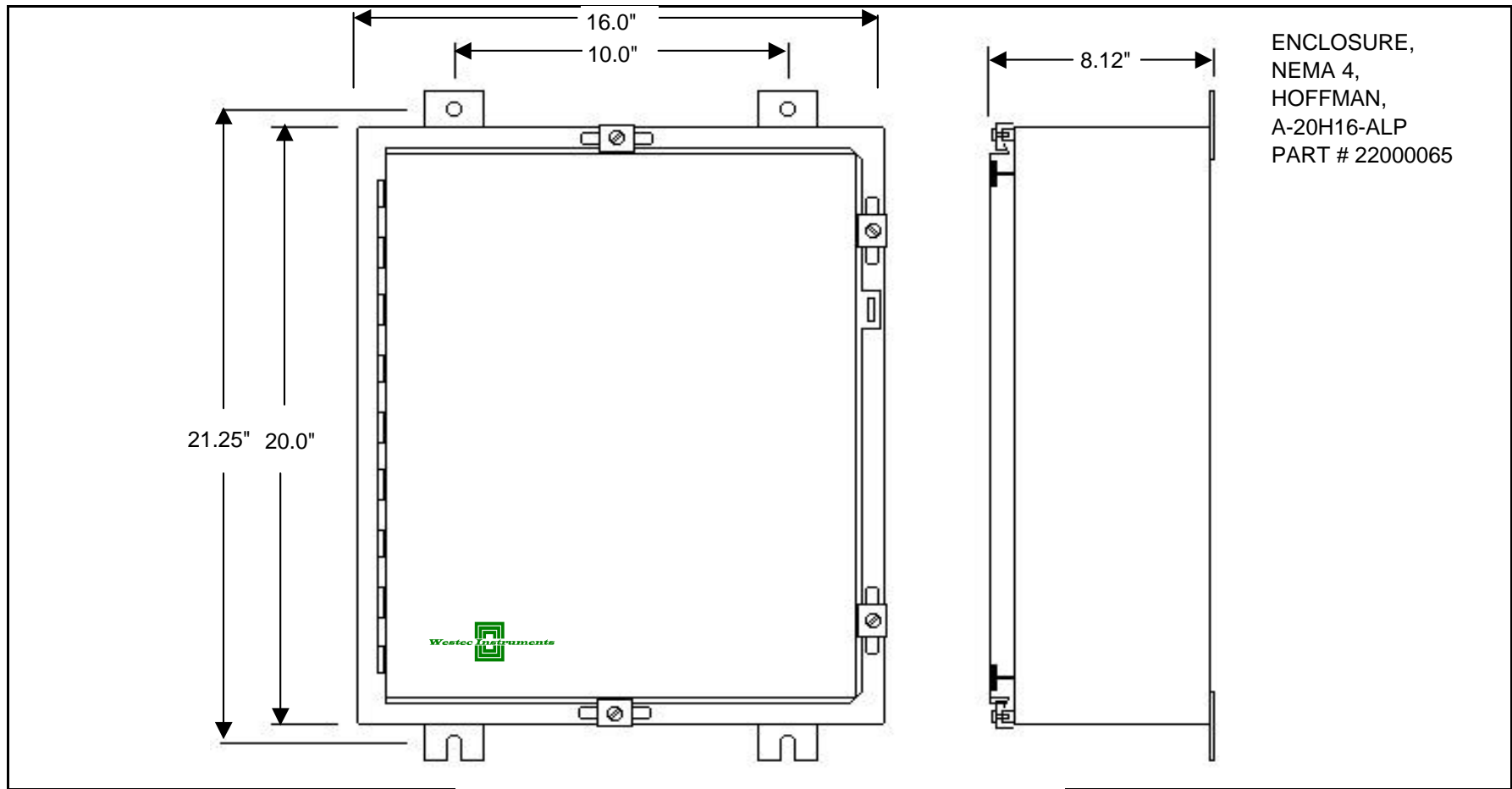

NO	DESCRIPTION	DATE
REVISIONS		
SCALE	NTS	DATE
DRAWN	WWC	2/22/99
CHECKED	WWC	2/22/99
APPROVED	WWC	2/22/99

TITLE
MILLMINDER ENCLOSURE OUTLINE DIMENSIONS

 <b>Westec Instruments</b>			
FILE	20153500	DRAWING NO.	REV
PLOT	1 = 1	1-1111Z-DU-B	0
JOB NO.			

FIGURE 1

# MILLPHONE

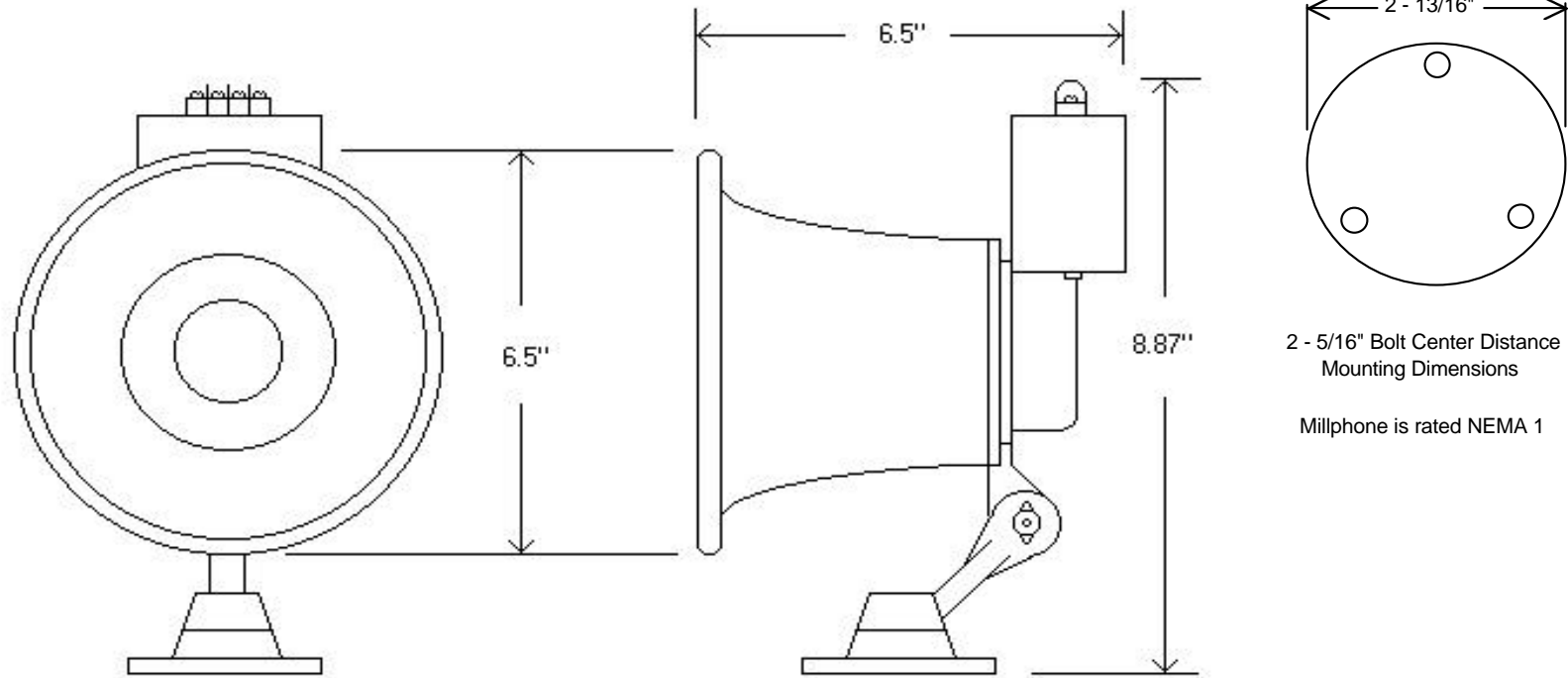

NO	DESCRIPTION	DATE
REVISIONS		
SCALE	NTS	DATE
DRAWN	WWC	2/22/99
CHECKED	WWC	2/22/99
APPROVED	WWC	2/22/99

TITLE
MILLPHONE ASSEMBLY OUTLINE DIMENSIONS



**Westec Instruments**

FILE	20153600	DRAWING NO.	REV
PLOT	1 = 1	1-20001Z-DU-B	
JOB NO.			

FIGURE 2

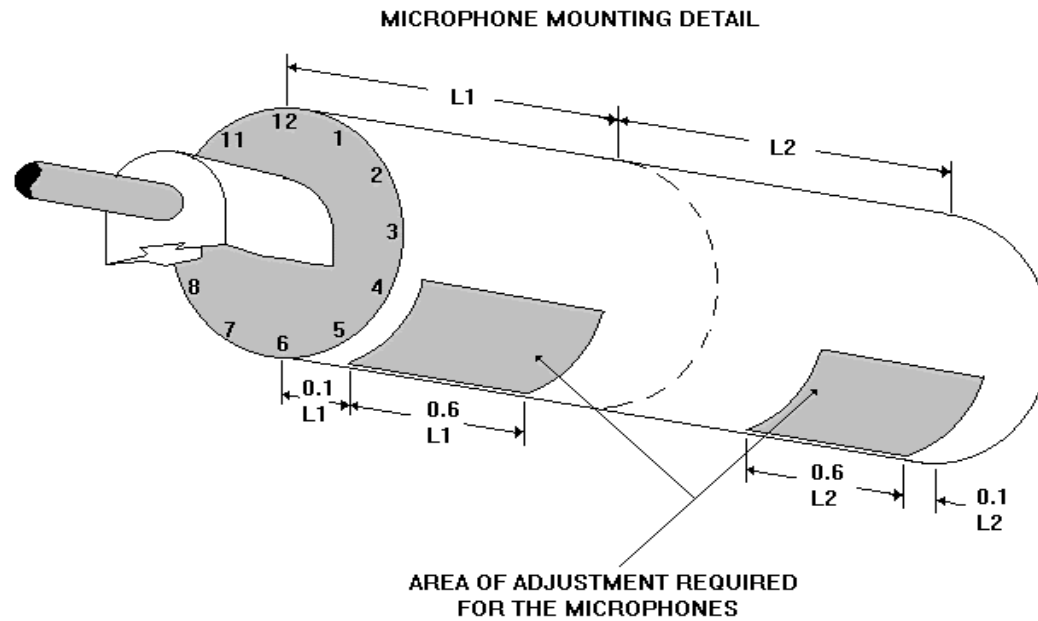

NO.	DESCRIPTION	DATE
<b>REVISIONS</b>		
SCALE	NTS	DATE
DRAWN	WWC	May 24, 1998
CHECKED	WWC	May 24, 1998
APPROVED	WWC	May 24, 1998

TITLE  
**MILLPHONE MOUNTING DETAILS  
MOUNTING DIMENSIONS**

FILE	DRAWING NUMBER	REV
PLOT 1 = 1	10A758	
JOB NO.		

FIGURE 3

NOTES:

1. NON - POLARIED UNIT
2. BELDEN 8760 OR EQUAL (MAXIMUM 1000 FEET)
3. SHIELD GROUNDED AT MILLPHONE
4. MICROPHONE ASSEMBLY IS RATED NEMA 1
5. INTERCONNECTION CABLE IS PROVIDED BY CUSTOMER
6. CHANNELS A - E ARE DETAILED ON MODULE RACK DRAWING

THE AUXILLARY TERMINALS ARE POWER FOR AN EXTERNAL DEVICE SUCH AS A CIRCULAR CHART RECORDER LOCATED NEXT TO THE MILLMINDER TO TRACK A BALL MILL. THIS VOLTAGE OUTPUT IS CREATED BY THE MODULE RACK.

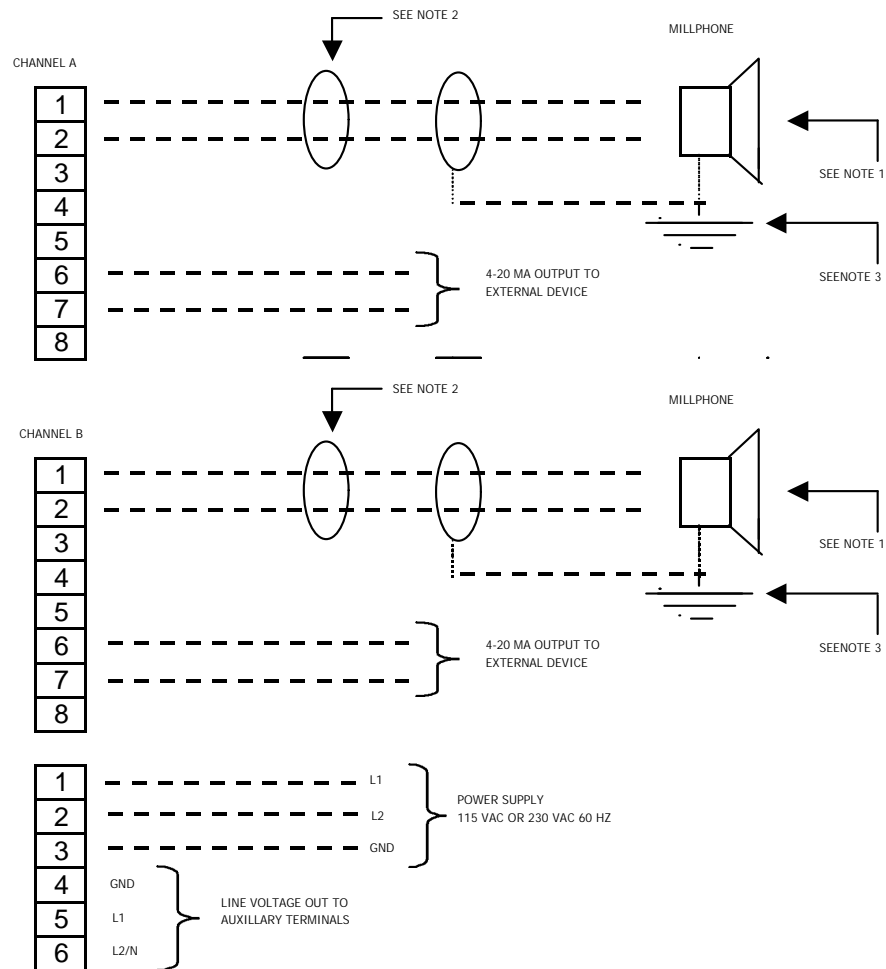

1	Added notes	6/4/00
NO	DESCRIPTION	DATE
REVISIONS		
SCALE	NTS	DATE
DRAWN	WWC	6/4/00
CHECKED	WWC	6/4/00
APPROVED	WWC	6/4/00

TITLE	<b>MILLMINDER W / 2 MILLPHONES INTERCONNECTION DIAGRAM</b>	
-------	--	--

FILE 20290900	DRAWING NO.	REV
PLOT 1 = 1	1-11112Z-DI-B	1
JOB NO.		

FIGURE 4

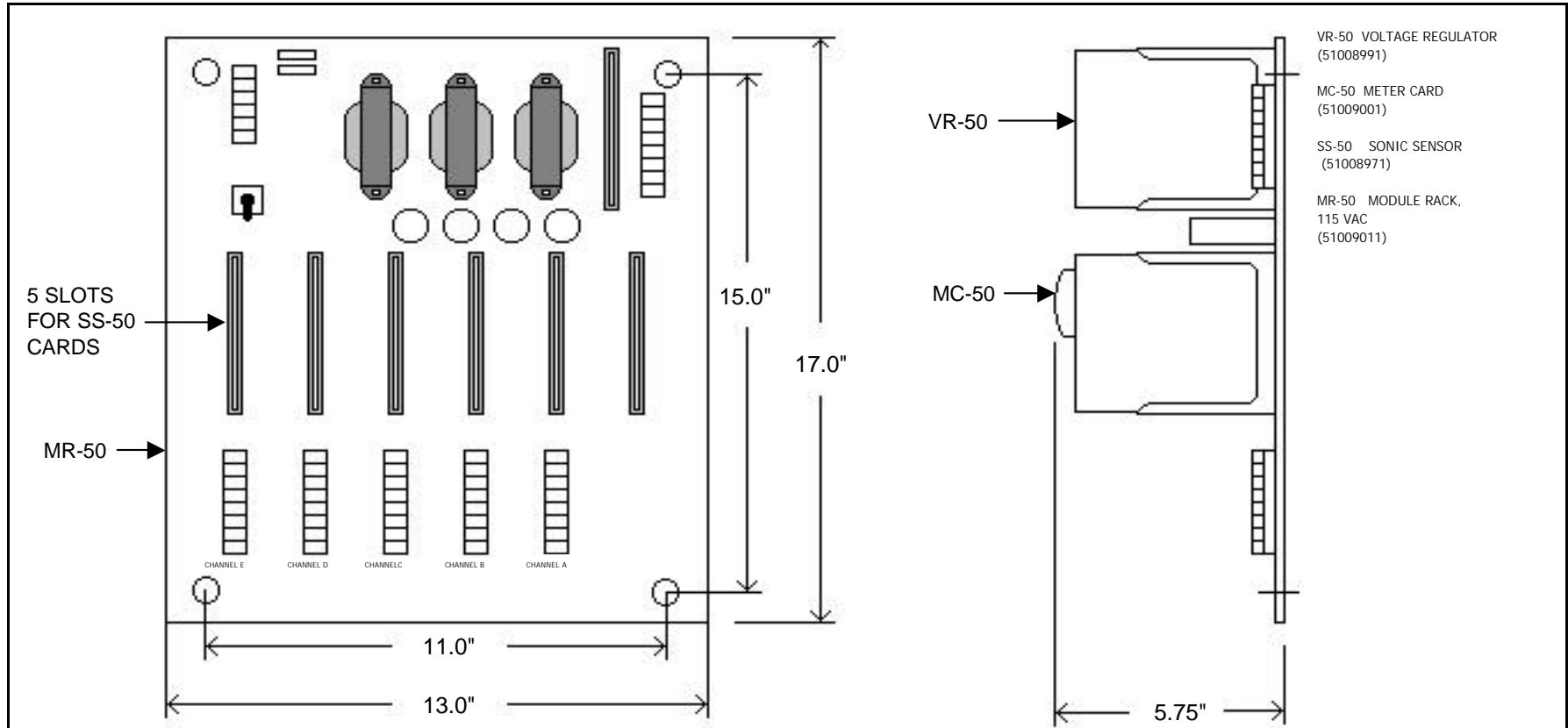

NO	DESCRIPTION	DATE
REVISIONS		
SCALE	NTS	DATE
DRAWN	WWC	2/22/99
CHECKED	WWC	2/22/99
APPROVED	WWC	2/22/99

TITLE  
**MODULE RACK - OPEN STYLE**  
 OUTLINE DIMENSIONS



**Westec Instruments**

FILE	20074301	DRAWING NO.	REV
PLOT	1 = 1	1-10111Z-DU-B	0
JOB NO.			

FIGURE 5

SONIC SENSOR CARD SS-50 OUTLINE DIAGRAM

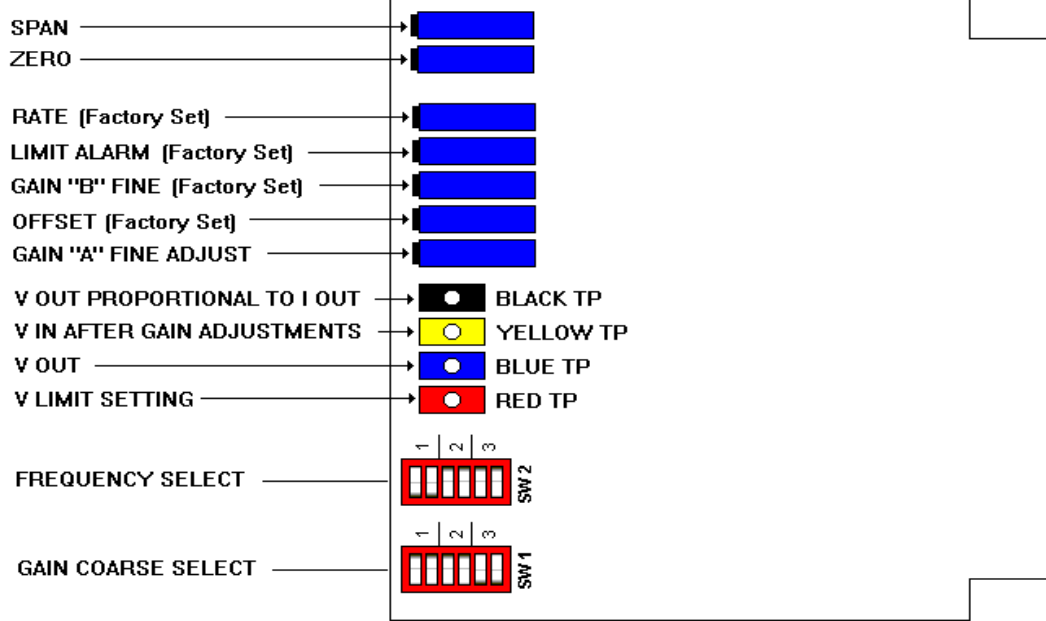

SW1	POSITION	CLOSE	OPEN	GAIN
	1	1,2	3,4,5,6	.25 TO 1.62
	2	3,4	1,2,5,6	1.25 TO 8.12
	3	5,6	1,2,3,4	8.31 TO 54

SW1	POSITION	CLOSE	OPEN	FREQUENCY
	1	1,2	3,4,5,6	3.3 KHZ
	2	3,4	1,2,5,6	1.0 KHZ
	3	5,6	1,2,3,4	CUSTOM

1	Changed SW1 & SW2	09/20/02
NO.	DESCRIPTION	DATE
REVISIONS		
SCALE	NTS	DATE
DRAWN	WWC	09/20/02
CHECKED	WWC	09/20/02
APPROVED	WWC	09/20/02

TITLE  
**SS-50 SONIC SENSOR CARD  
 ADJUSTMENT DETAILS**

FILE	DRAWING NUMBER	REV
PLOT 1 = 1	1-10111Z-DT-B	1
JOB NO.		

FIGURE 6



FIGURE 2